

FS-300

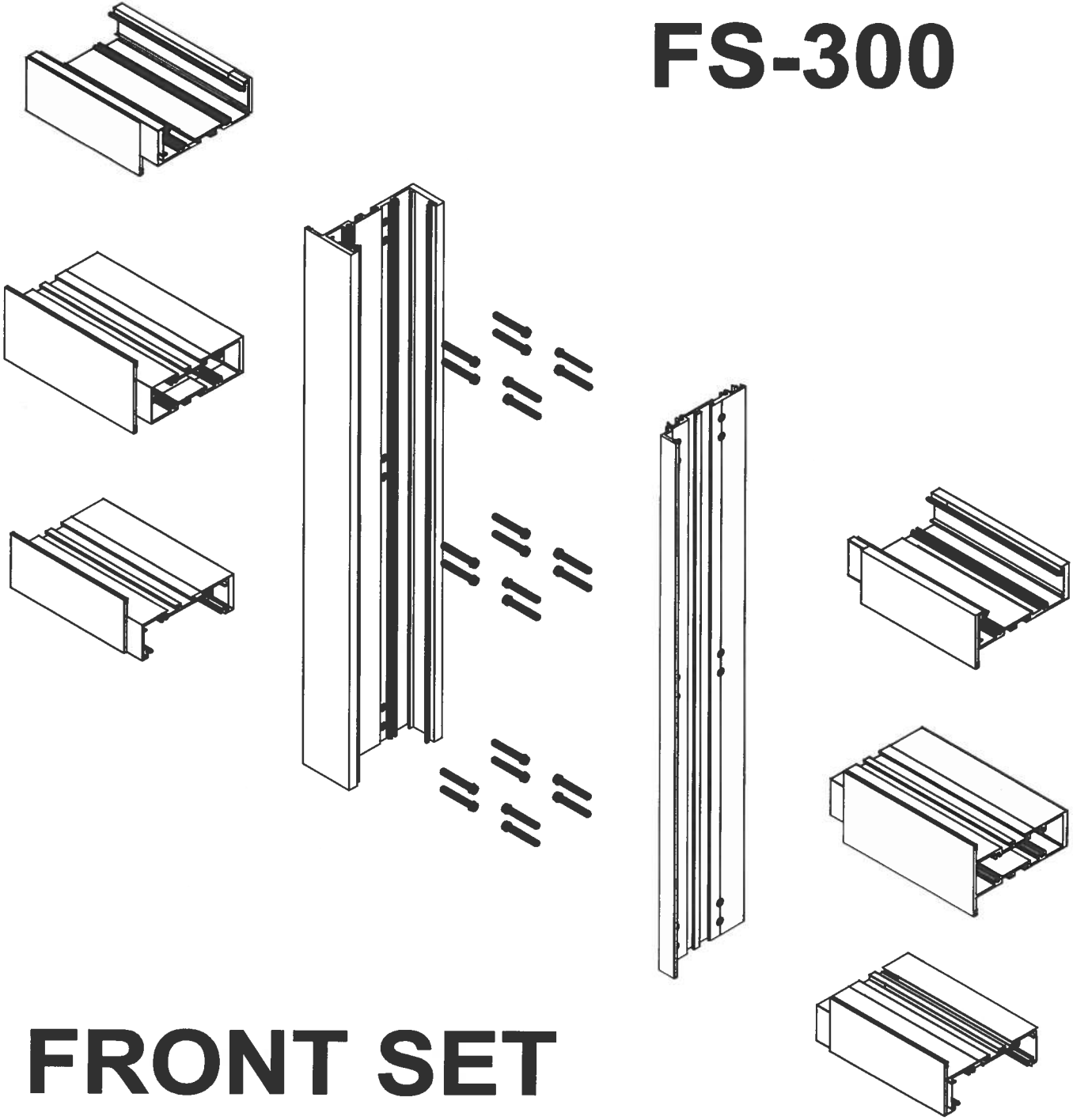

FRONT SET SYSTEM

INSTALLATION INSTRUCTIONS

CONTENTS

PAGE

GENERAL INSTALLATION NOTES..... 3

PARTS IDENTIFICATION..... 4 - 5

TYPICAL WINDOW DETAILS..... 6 - 8

TYPICAL SIDELITE DETAILS..... 9

FABRICATION: ASSEMBLY SCREW..... 10

FABRICATION: SPECIAL NOTCHES..... 11

SYSTEM ASSEMBLY (TYPICAL)..... 12 - 13

INSTALLATION..... 14 - 16

GLAZING: 9/16" THK. LAM. GLASS..... 17

GLAZING: 1 5/16" THK. LAM./ INSUL.GL..... 18

GLAZING: 1 5/16" THK. LAM./INSUL. GL. THERMAL BARRIER..... 19

STEEL REINFORCEMENT..... 20

PATENT PENDING:

THE FRONT SET (FS300) HAS A PATENT PENDING FOR ITS INNOVATIVE SEAMLESS DESIGN. ANY ATTEMPT TO COPY THIS DESIGN WOULD CONSTITUTE AN INFRINGEMENT ON ALDORA'S INTELLECTUAL PROPERTY.



GENERAL INSTALLATION NOTES







1. **Safety-** Safety should be the primary concern throughout the installation process. Keep the installation areas clear of debris and obstructions. Lift and carry products carefully using proper lifting procedures. Always wear safety gear as determined by products and or jobsite conditions.
2. **Building Code-** The Building Code determines the requirements of products to be used on a project. Aldora manufactures products to the installer's specifications; however, Aldora does not assume any responsibility for the suitability of its products for any project. It is the responsibility of the glazier to ensure each product meets the project requirements.
3. **Openings-** Measure the openings to determine if they match the building plans. Notify the General Contractor immediately to correct any deviation.
4. **Shop drawings-** Review shop drawings to ensure all materials have been manufactured in accordance with the shop drawings.
5. **Receiving-** Inspect all products upon receipt. Do not install any damaged or deficient products. Return to Aldora immediately for correction.
6. **Protection-** Protect all materials from damage including cement, stucco, paint, mud or other abrasives or chemicals. Materials need to be protected properly before, during and after installation.
7. **Field testing-** Glaziers must fully understand all sealing procedures in advance of installation. If installed correctly and properly sealed, Aldora's products will achieve satisfactory results during field test. Aldora will not accept any responsibility for installation deficiencies.



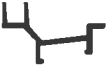

Pre-installation

1. **Checklist-** Working from a checklist, bring all necessary documents, tools, equipment and supplies to the jobsite.
2. **Products-** Review all products versus the shop drawings to ensure everything is at the jobsite. Examine mark numbers to verify proper products per opening.
3. **Pre-glazed units-** With multiple panel openings, identify the panel with two jambs for the opening, this is typically the starting panel for the left hand side of the opening (outside looking in).
4. **Sealants-** Ensure compatibility of the sealant with all products involved.
5. **Anchors-** Verify anchors supplied match shop drawings.
6. **Opening preparation-** Clean opening of all debris and examine for level and plumb.

FS-300 SYSTEM

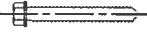
PARTS IDENTIFICATION (Continued)

PROFILE	PART #	DESCRIPTION
	SMI-G01	INTERIOR GLAZING GASKET
	SMI-G02	SINGLE FACE FOAM TAPE 3/8" X 1/2" (OPTION)
	SMI-G13	SPACER/ RETAINER OUTER GASKET
	SMI-SB03	SETTING BLOCK 1/4" X 1/2" X 2" LG. / SPACER 1" LG. (OPTION)
	SMI-SB07	SETTING BLOCK 1/4" X 1 1/4" X 4" LG.
	SMI-P03	TEMPORARY GLASS STOP
	SMI-P08	TEMPORARY GLASS STOP

PROFILE	PART #	DESCRIPTION
		ASSEMBLY SCREW #12 X 1 1/2" LG. HX. WASHER SMS. ST/ST
		ASSEMBLY SCREW #12 X 1 1/2" LG. FT. HD. SMS. ST/ST
		MULLION SCREW 1/4-20 X 2 1/4" LG. FT. HD. MACHINE BOLT ST/ST
		NUTS 1/4-20 HEX. ST/ST

5 INSTALLATION INSTRUCTIONS

Aldora's Front Set (FS-300) can be assembled as a screw spline system or with shear block assembly. This enables the glazier to assemble based on their preference or possible unique job site conditions. The screw spline assembly can be pre-fabricated and pre-glazed for multi-unit panels using the jamb/mullion member and the fin snap. The shear block is often utilized for field assembly.

Glazing represented below is 9/16" laminated glass.

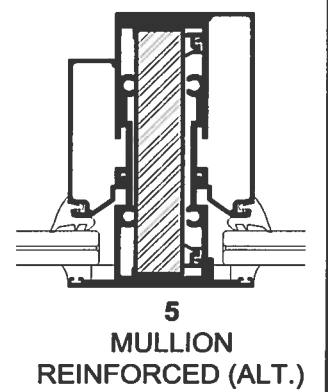
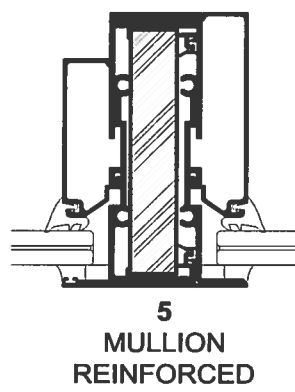
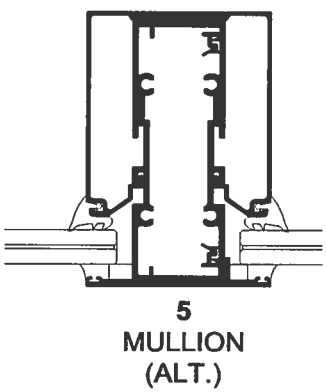
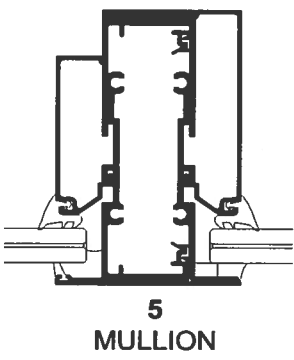
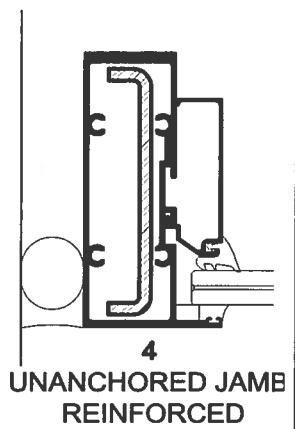
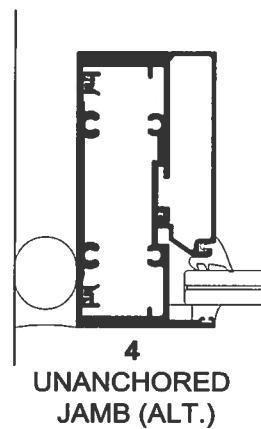
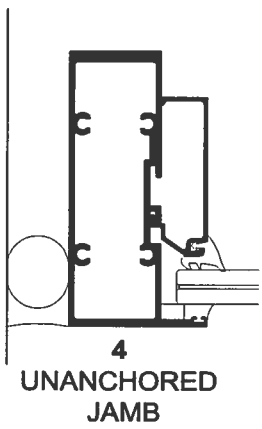
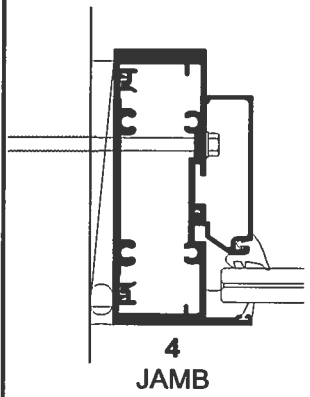
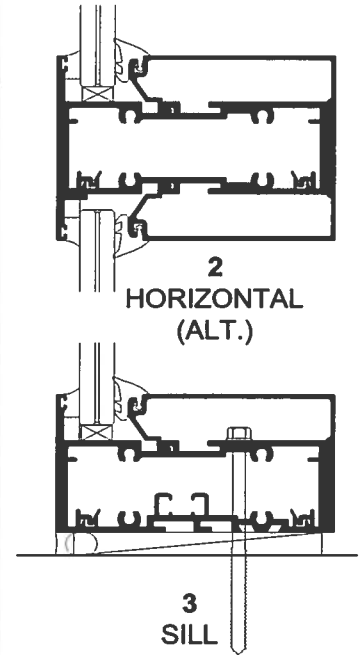
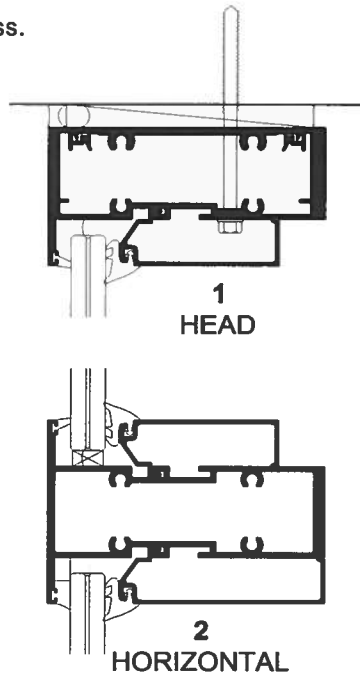
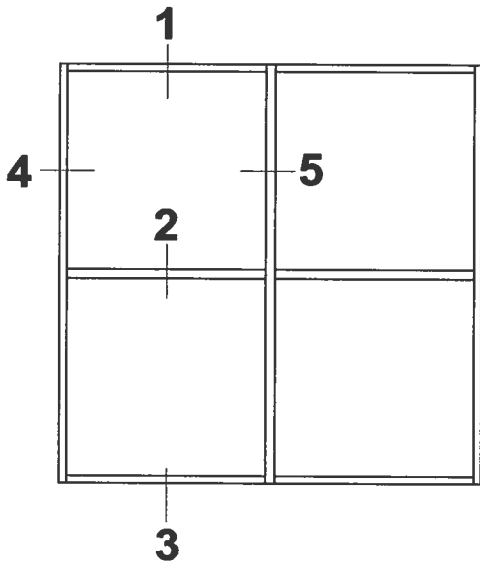

FS-300 SYSTEM

TYPICAL WINDOW DETAILS: 1 5/16" THK. LAM./ INS. GL.

Aldora's Front Set (FS-300) can be assembled as a screw spline system or with shear block assembly. This enables the glazier to assemble based on their preference or possible unique job site conditions. The screw spline assembly can be pre-fabricated and pre-glazed for multi-unit openings using the jamb/mullion member and the fin snap. The shear block is often utilized for field assembly.

Glazing represented below is 1 5/16" laminated-insulated glass.

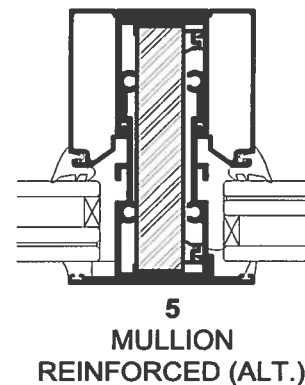
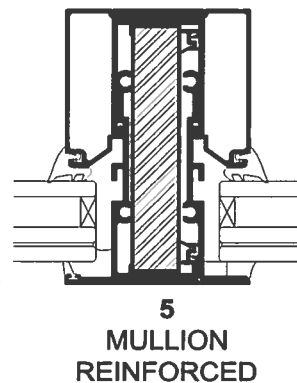
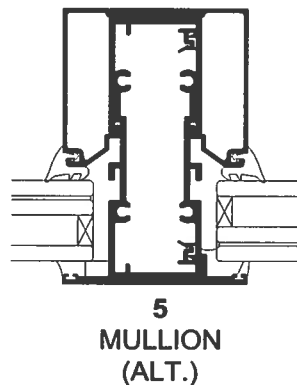
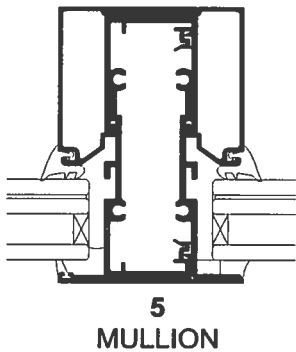
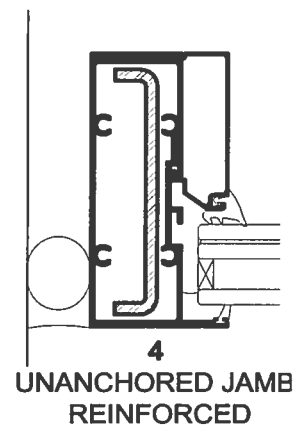
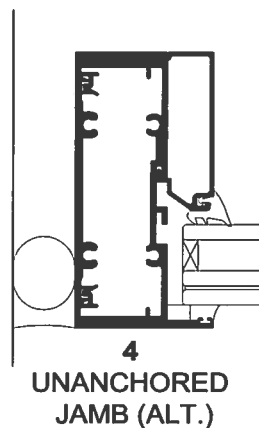
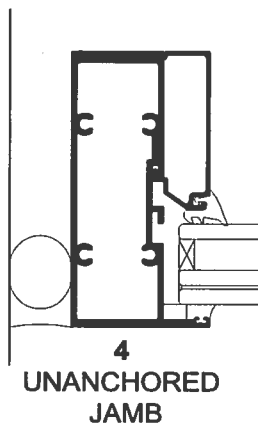
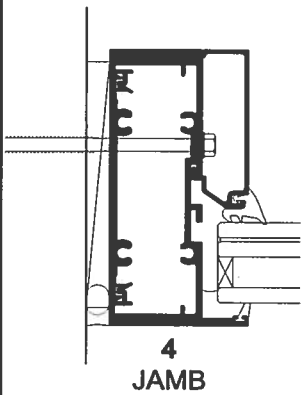
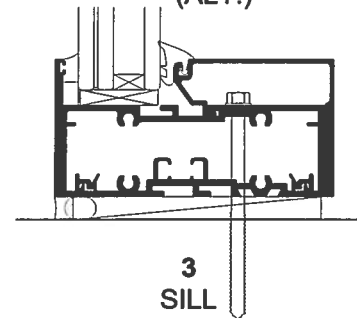
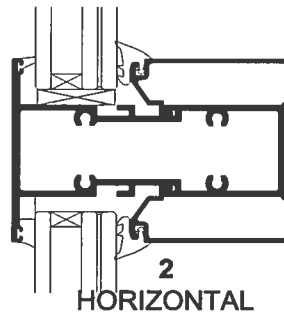
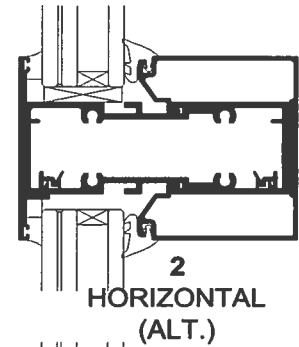
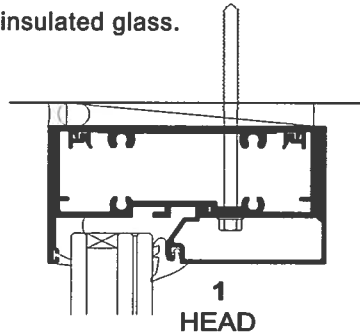
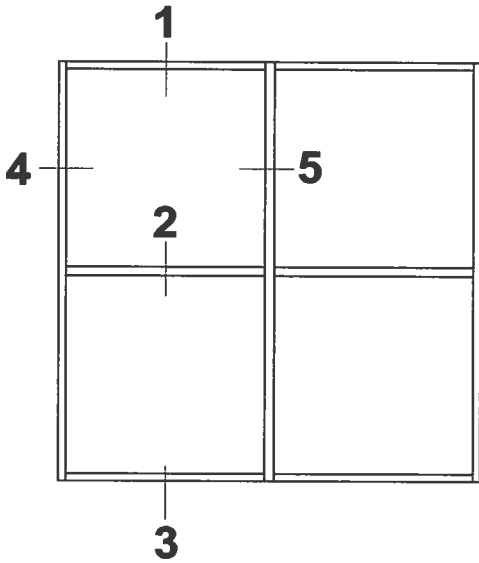

7 INSTALLATION INSTRUCTIONS

FS-300 SYSTEM

TYPICAL WINDOW DETAILS: 1 5/16" THK. LAM./ INS. GL. & T.B.

Aldora's Front Set (FS-300) can be assembled as a screw spline system or with shear block assembly. This enables the glazier to assemble based on their preference or possible unique job site conditions.

The screw spline assembly can be pre-fabricated and pre-glazed for multi-unit openings using the jamb/mullion member and the fin snap. The shear block is often utilized for field assembly.

Glazing represented below is 1 5/16" laminated-insulated glass in the thermally broken variation of the FS-300.

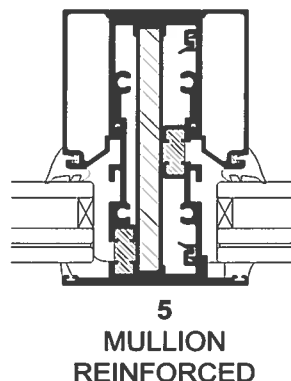
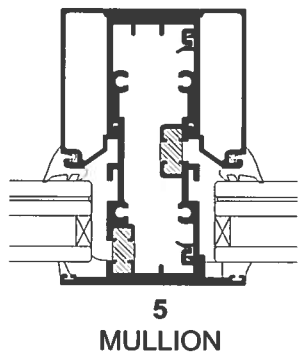
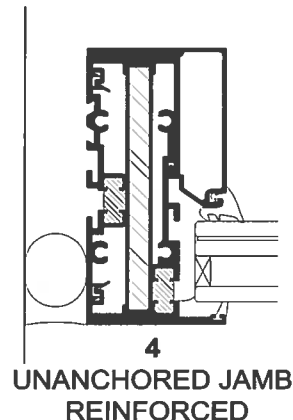
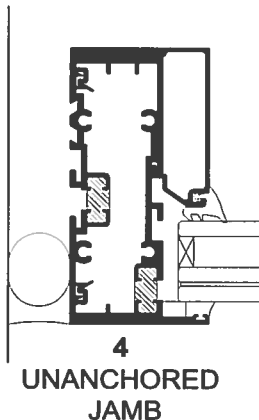
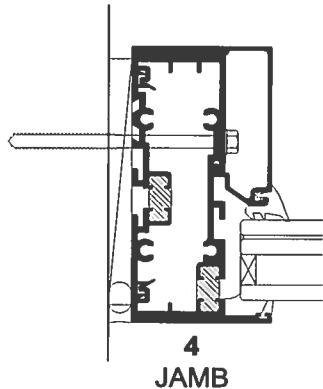
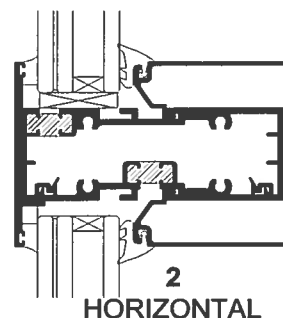
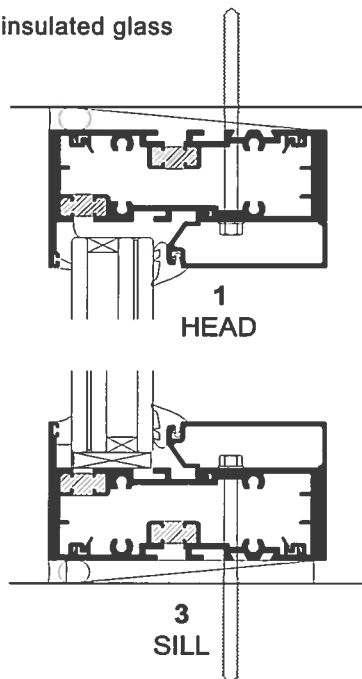
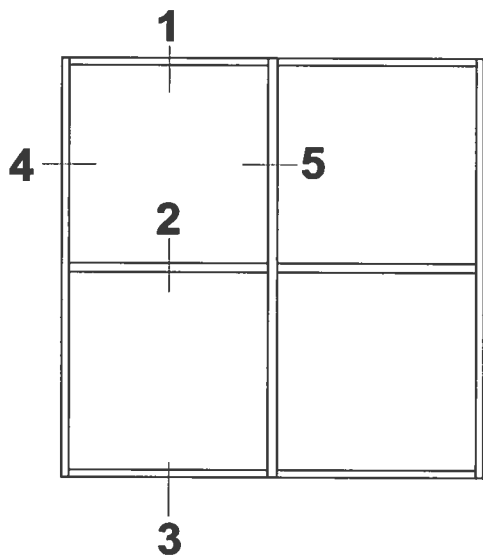

88 INSTALLATION INSTRUCTIONS

FS-300 SYSTEM

TYPICAL WINDOW DETAILS: AT DOOR & TRANSOM.

The open back jamb of Aldora's K2 Doors series accepts the fin snap of the FS-300. Transom assembly for the Front Set is shown below with $\frac{9}{16}$ " glazing and $1\frac{5}{16}$ " glazing.

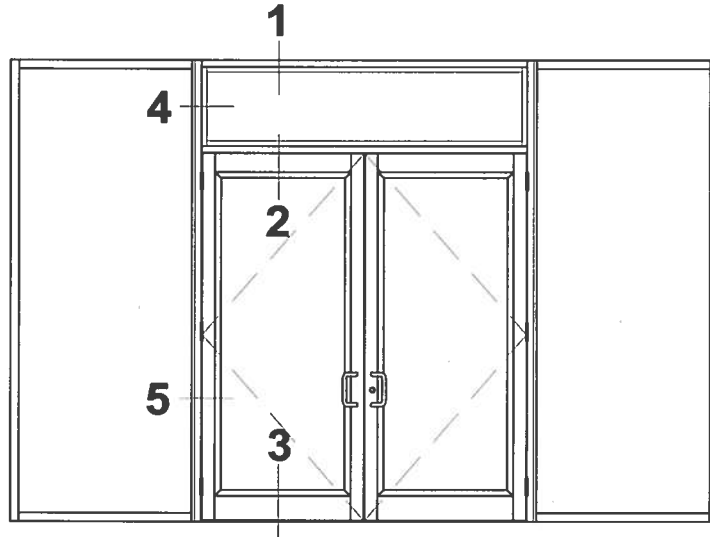

1
HEAD AT
TRANSOM

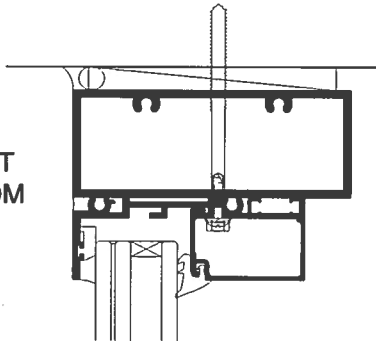

4
SIDE LITE AT
DOOR MULLION

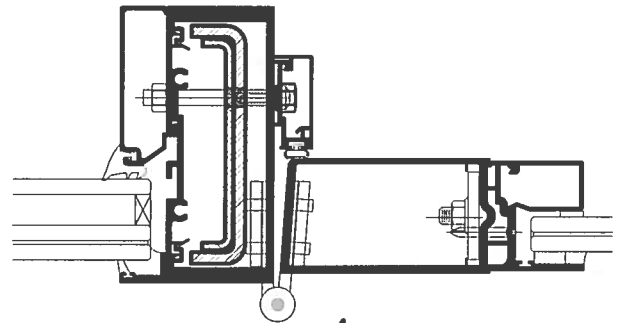

2
DOOR AT
TRANSOM

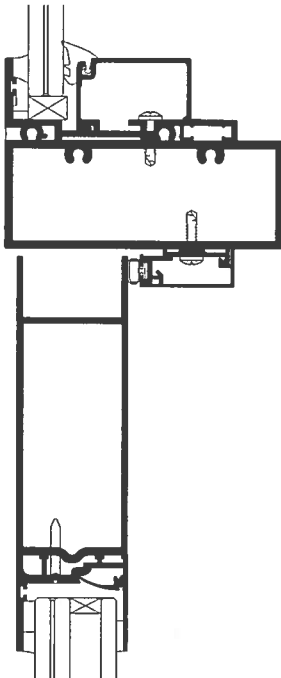

3
THRESHOLD

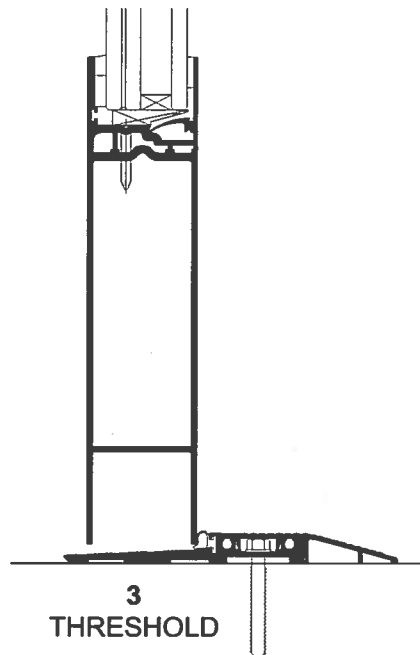

5
SIDE LITE AT
TRANSOM

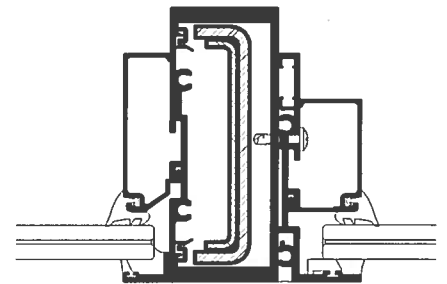

FS-300 SYSTEM

FABRICATION: ASSEMBLY SCREW

Determine opening dimensions by measuring width and height and reduce each by 3/8" on all sizes. This allows for shim spacing and perimeter sealant. If the opening is not square, use the smallest dimension for each measurement before deducting for shim space.

Vertical members are cut at the frame height dimension. Horizontal members are cut to fit within vertical members. Where intersecting with the verticals members, the fin of the horizontal must be notched (see details on page 11). Assembly holes are drilled in the verticals framing member wherever horizontals are adjoined.

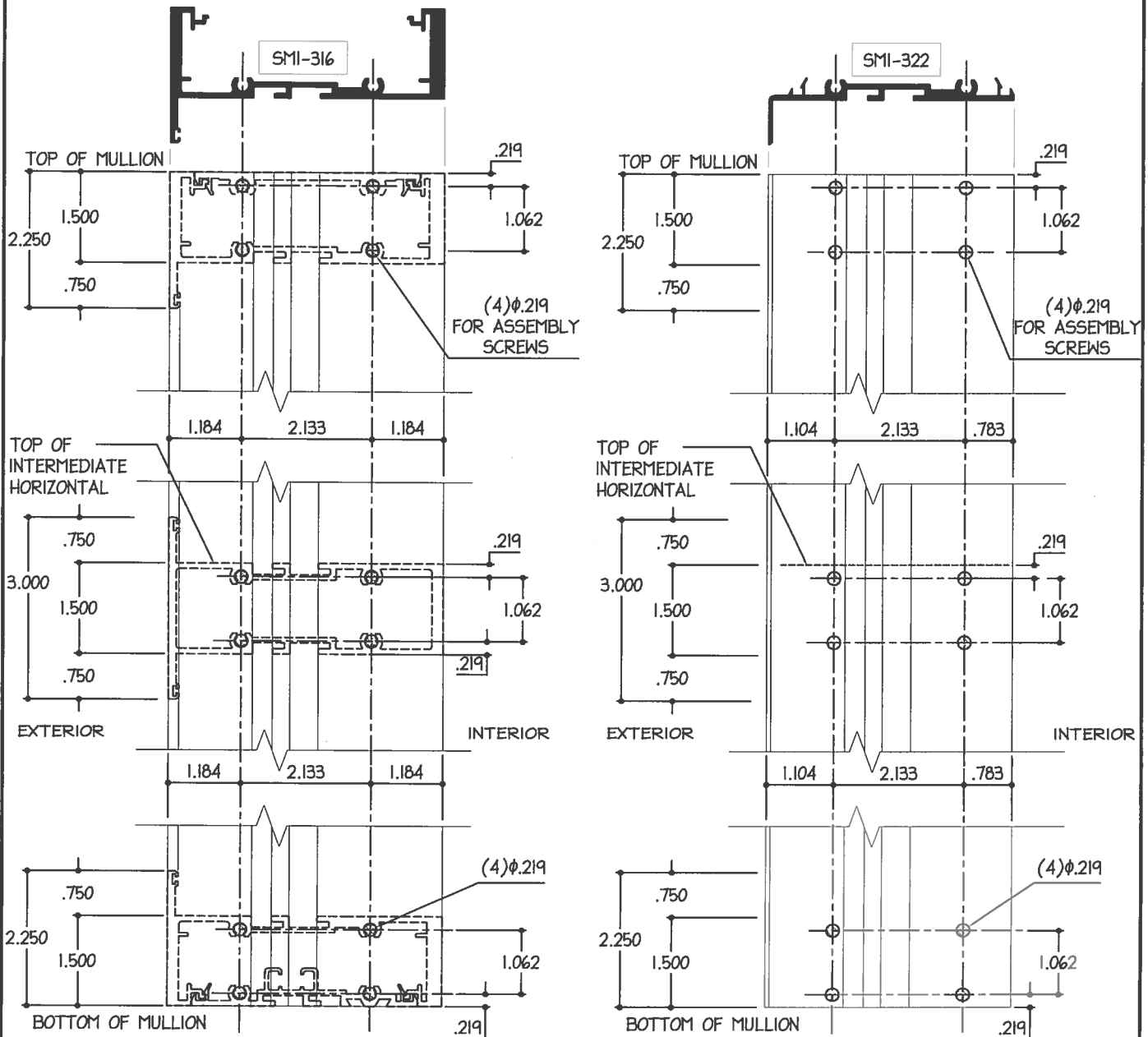

FS-300 SYSTEM

FABRICATION: SPECIAL NOTCHES

INSTALLATION INSTRUCTIONS

Notching details for the horizontal framing member shown below using the intermediate mullion, part number SMI-319. The notching for the alternate horizontal framing members SMI-311, SMI-311T and SMI-316 is the same.

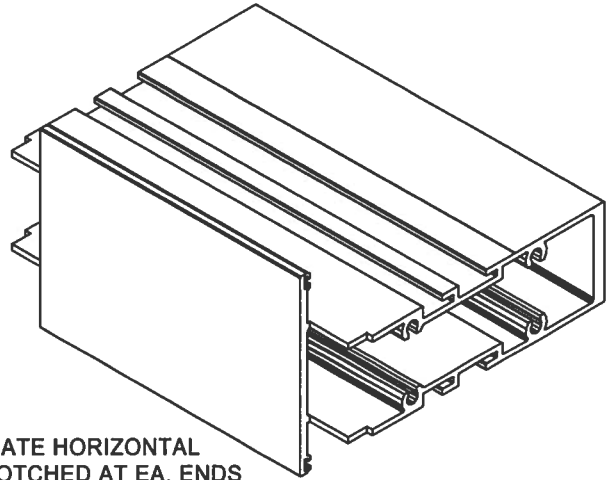

INTERMEDIATE HORIZONTAL
TYPICAL NOTCHED AT EA. ENDS

NOTCHED SPECS
SIDE VIEW.

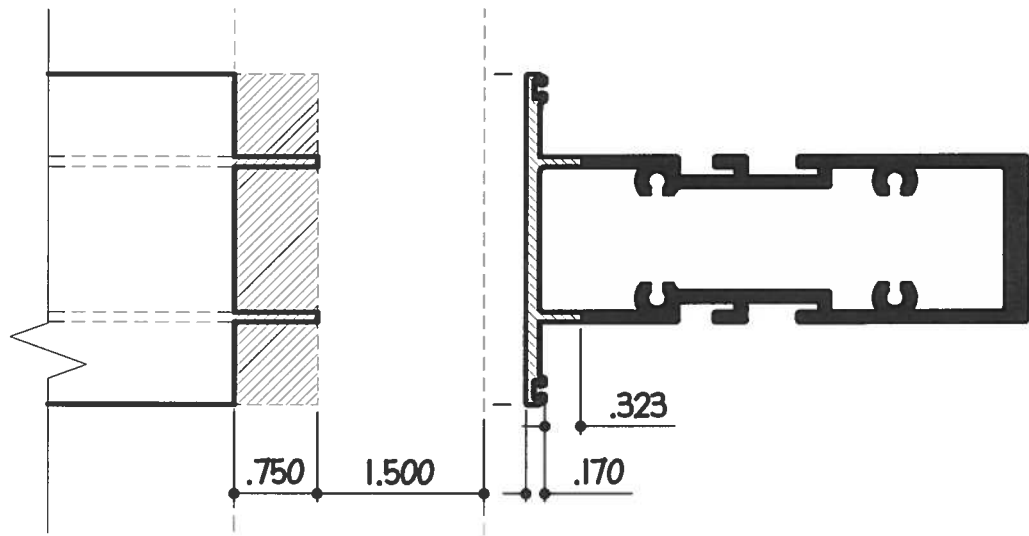

NOTCHED SPECS
PLAN VIEW.

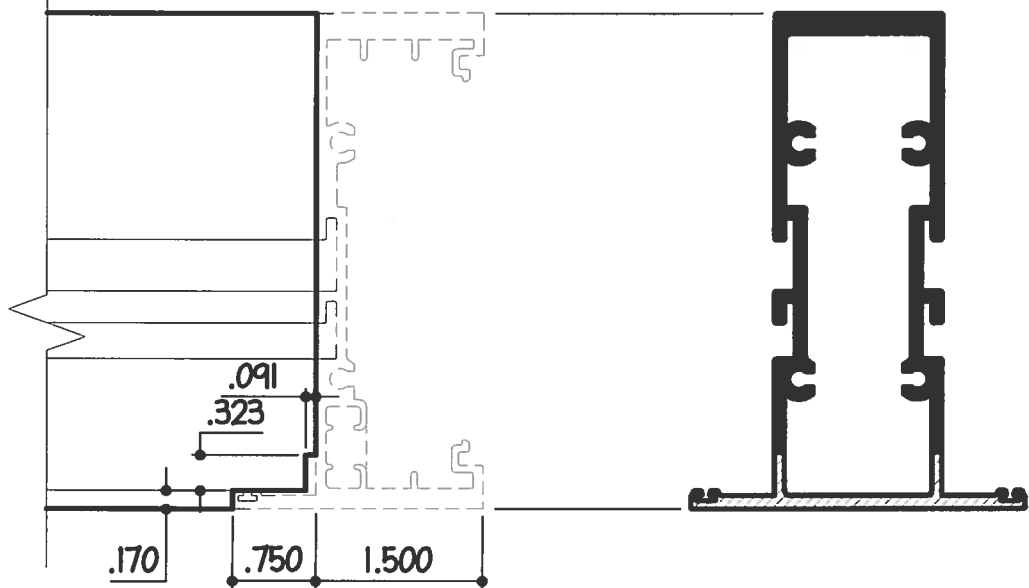

Assembly Instructions

Apply sealant to the ends of the horizontal framing members prior to fastening to the vertical jambs or mullions. This will provide the joint seal necessary to prevent water penetration.

Affix the horizontal members to the vertical framing member by screwing four (4) # 12 X 1 1/2" S.S. hex head screws into each joint location as shown below.

The fabricated frame can be pre-glazed prior to shipping.

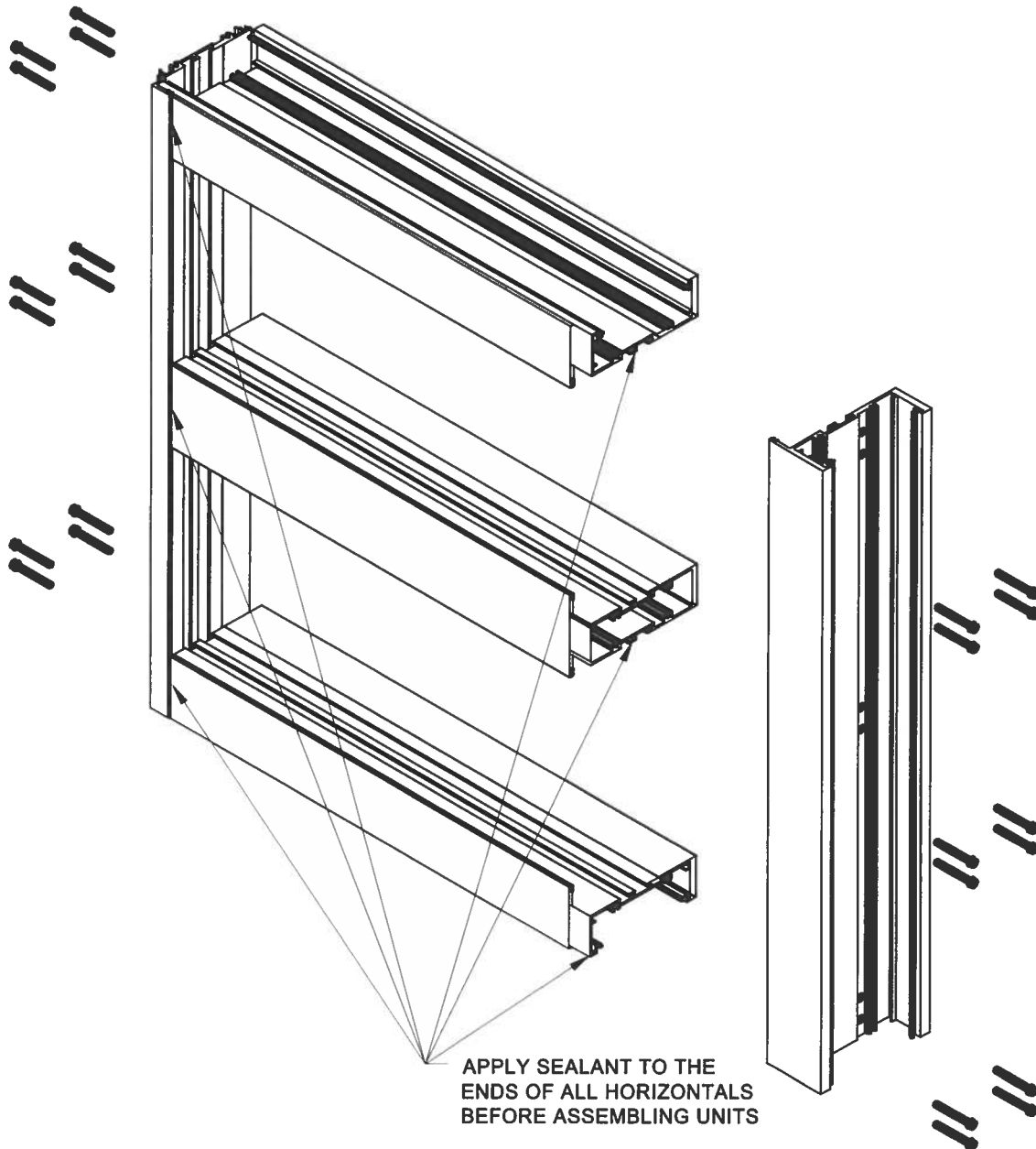

Assembly

When assembling the horizontal framing member to the vertical, apply recommended sealant to the front fin surface and the edge of the horizontal extrusion. Extend the sealant around the ends of all horizontal members to ensure a uniform seal between the two framing members.

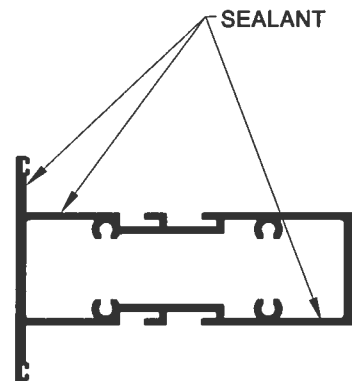
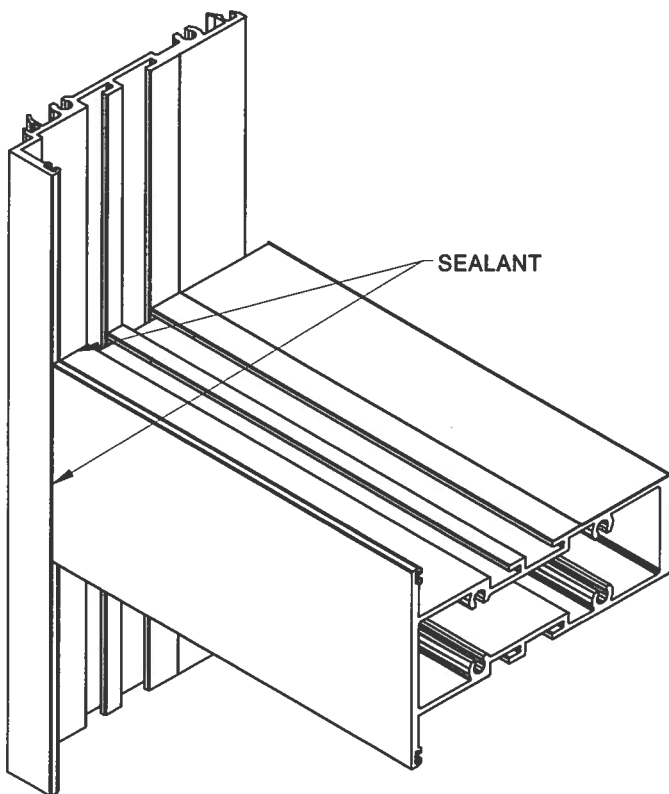
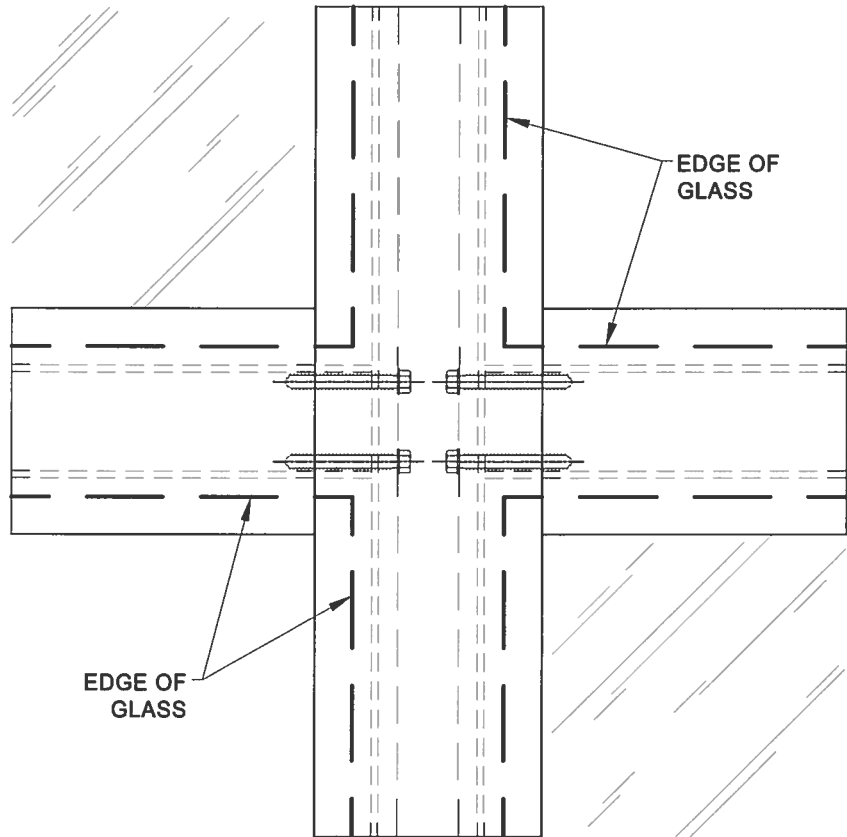

Installation Instructions

When setting the sill member, create a perimeter seal gap by shimming the sill $\frac{1}{4}$ " above the substrate. Installation screws are spaced per the shop drawings and are located behind the glazing pocket. The installation screw is fastened through the sill and the plain snap and into the substrate. The screws will be covered by the glass stop after the unit has been glazed.

EXTERIOR

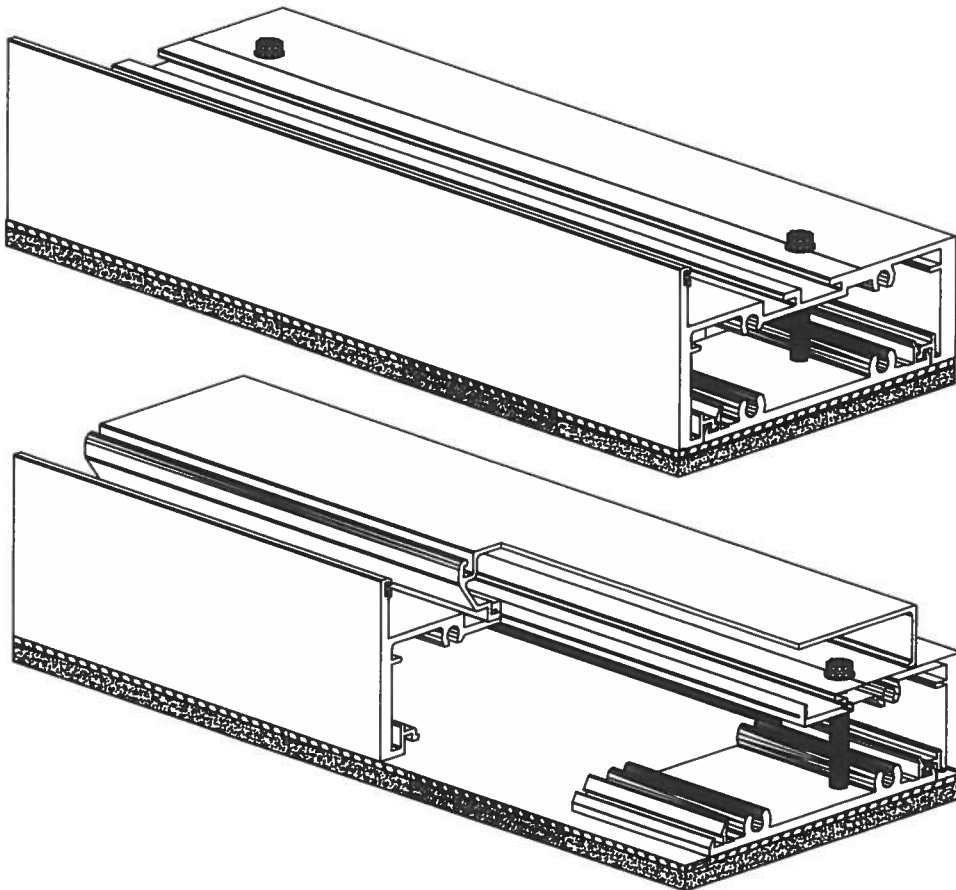
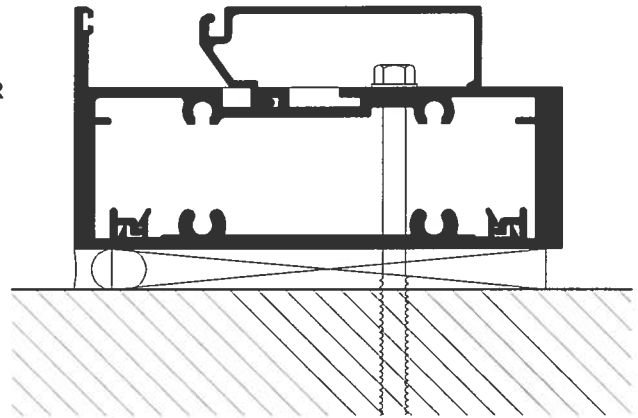

FS-300 SYSTEM

SYSTEM INSTALLATION (CONTINUED)

15 INSTALLATION INSTRUCTIONS

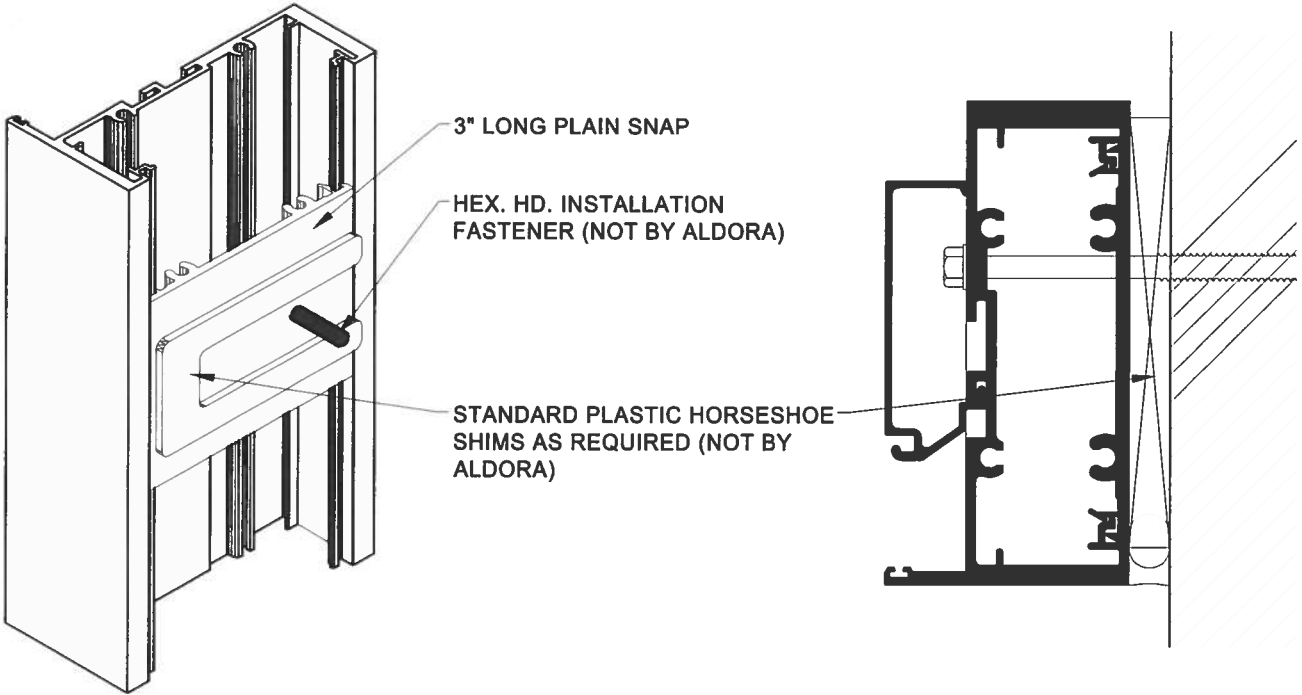

Installation Instructions (continued)

Use standard horseshoe shims to create the perimeter gap necessary for perimeter sealant to be applied. Shims are inserted around the installation screws between the plain snap and the substrate.

When installing multi-panel units, set the first panel (the panel with jambs on both verticals), then snap in the adjacent unit. Prior to snapping, run a sealant bead along the joint created at fin of both panels. Once snapped, fasten with installation screws at head and sill and repeat the process with each remaining panel until the opening is complete.

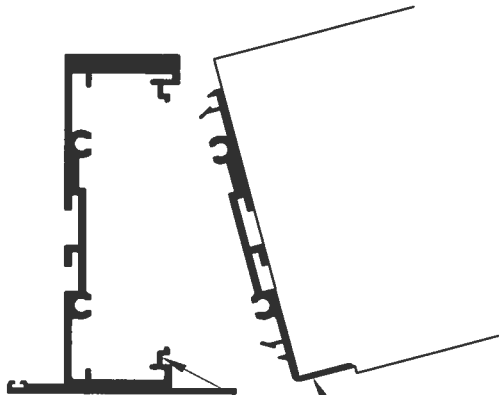

APPLY SEALANT PRIOR TO SNAP

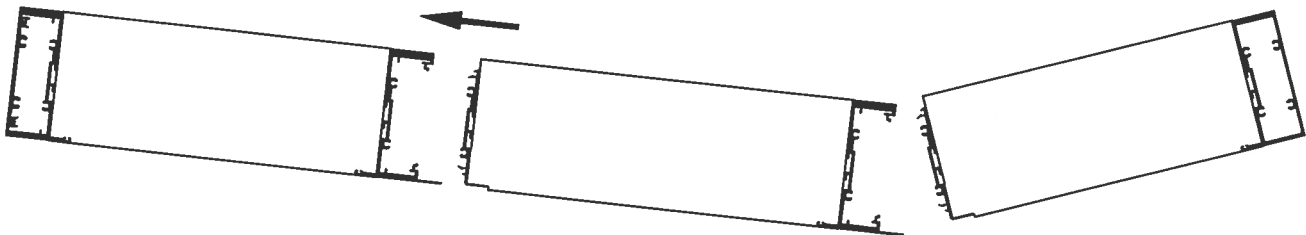

SNAPPING MULTI-PANELS UNIT

Installation Instructions (continued)

The FS-300 has two options for applying the specified glazing silicone to the glass and framing members. The same procedures can be used for $\frac{9}{16}$ " glazing, $1 \frac{5}{16}$ " glazing with the sacrificial lite outboard, or $1 \frac{5}{16}$ " glazing with the sacrificial lite inboard.

Option 1- Using exterior gasket/spacer

Run the gasket into the groove located on the fin of the framing member. Pump silicone into the pocket created by the gasket from the gasket to the base of the glazing pocket. The bead should be $\frac{1}{4}$ " in depth. Place the setting blocks and set the glass in the pocket. Insert the glass stop in the stop guide and wedge the glazing gasket between the glass and glass stop. Temporary glass stop may be used where screw inspections are required.

Option 2- Using traditional foam spacer tape

Adhere the foam spacer tape to the base of the glazing pocket and along the length of the framing member. Place setting blocks and set the glass in the glazing pocket. Insert the glass stop in the stop guide and wedge the glazing gasket between the glass and glass stop. Temporary glass stops may be used where screw inspections are required. From the outside, run the glazing silicone bead in the cavity between the glass and the fin of the framing member making sure to fill the entire cavity created by the foam spacer. Run this bead the length of the framing member. It is best to tool the silicone in order to allow water to run off vs. pool on top of the bead.

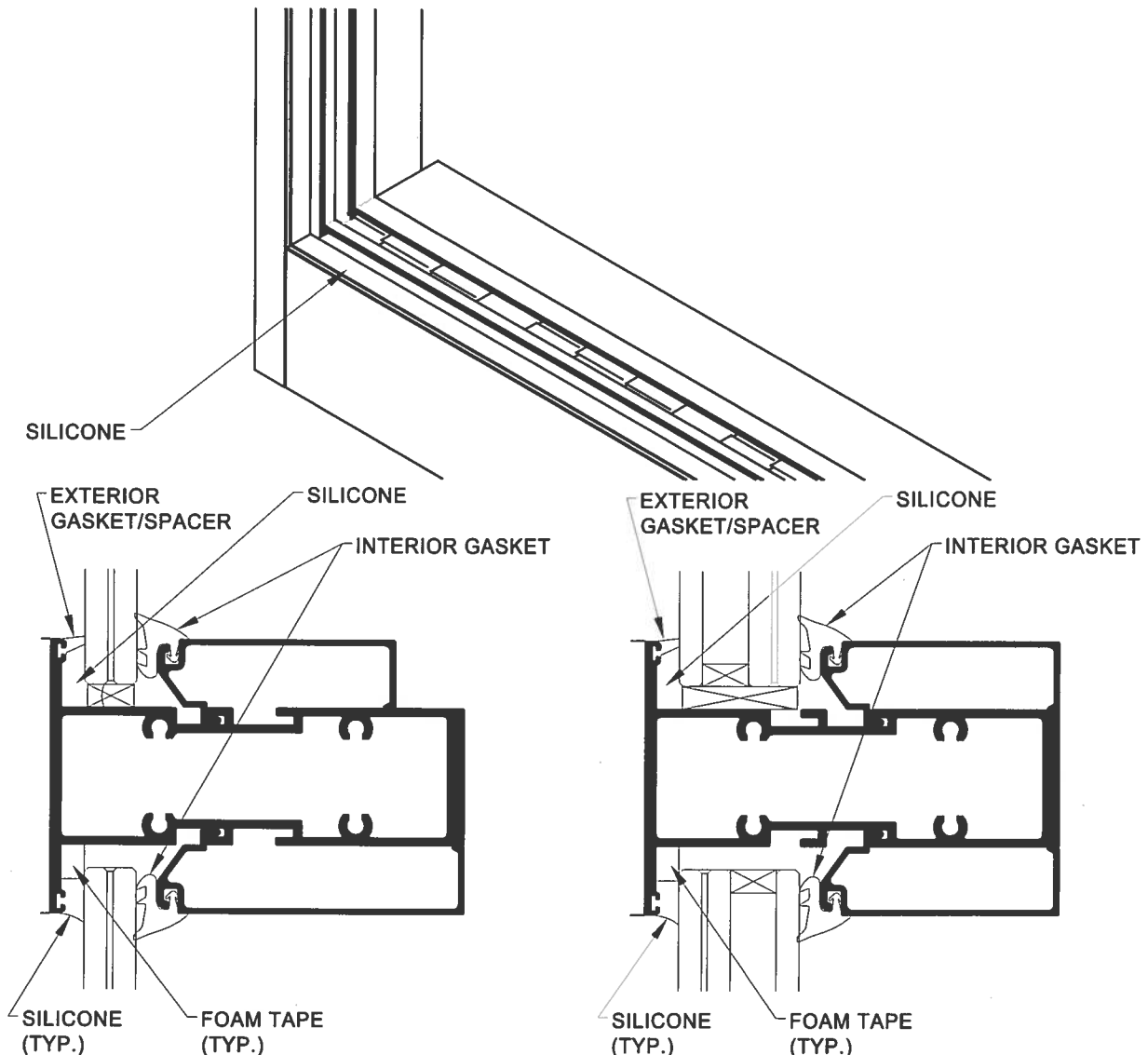

FS-300 SYSTEM

GLAZING: 9/16" THK. LAM. GLASS

The Front Set has two variable glass stop locations. When the front glass stop is selected, the glazing pocket measures approximately 1" in width. This is setting for laminated hurricane resistant glazing when using 9/16" glass. Please note that Aldora offers two different glass stop for this setting; a standard glass stop (SMI-312) that creates an interior reveal, or the extended glass stop (SMI-314) which provides a flush profile on the interior. Please specify which glass stop you choose when ordering.

TYPICAL GLASS SIZE IS DAYLITE OPENING (D.L.O.) + 1"

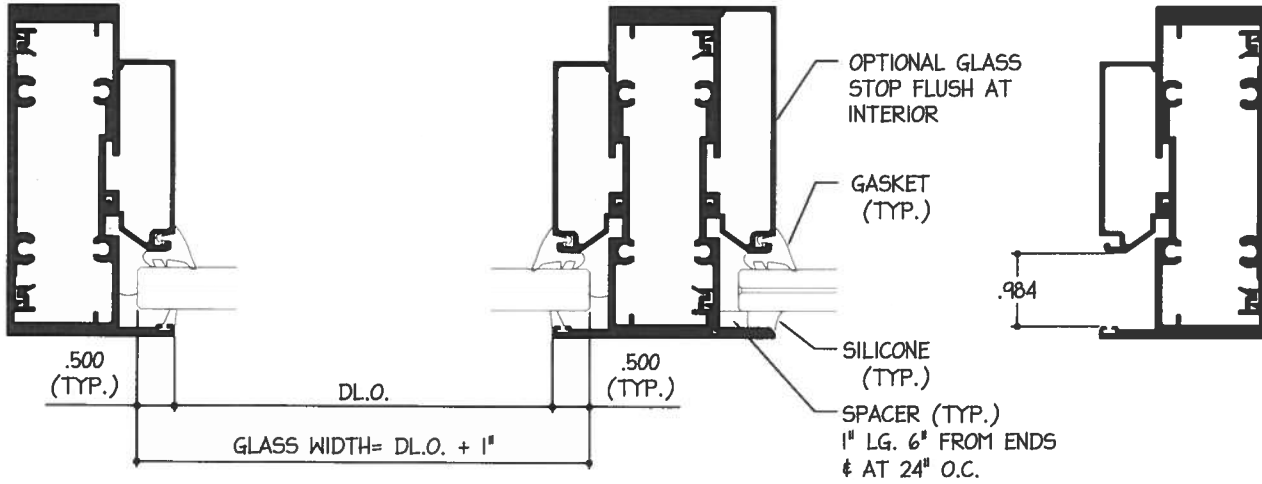

NOMINAL INFILL THICKNESS	EXTERIOR GASKET	INTERIOR GASKET
9/16"	SMI-G13	SMI-G01
9/16"	SMI-SB03	SMI-G01

EXTERIOR GLAZING GASKETS:



SMI-G13



SMI-SB03

INTERIOR GLAZING GASKET:



SMI-G01

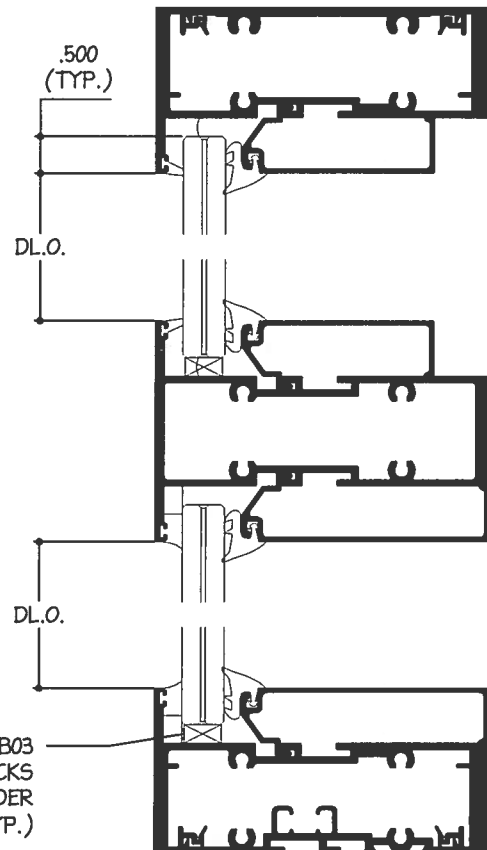

FS-300 SYSTEM

GLAZING: 1 5/16" THK. LAM./ INSULATED GLASS

The Front Set has two variable glass stop locations. When the rear glass stop is selected, the glazing pocket measures approximately 1 3/4" in width. This is setting for insulated laminated hurricane resistant glazing when using 1 5/16" glass. The standard glass stop (SMI-312) creates a flush profile on the interior. Please note that the front set can be glazed with the sacrificial lite (1/4" portion of the insulated laminated glass) to the interior or the exterior.

TYPICAL GLASS SIZE IS DAYLITE OPENING (DL.O.) + 1"

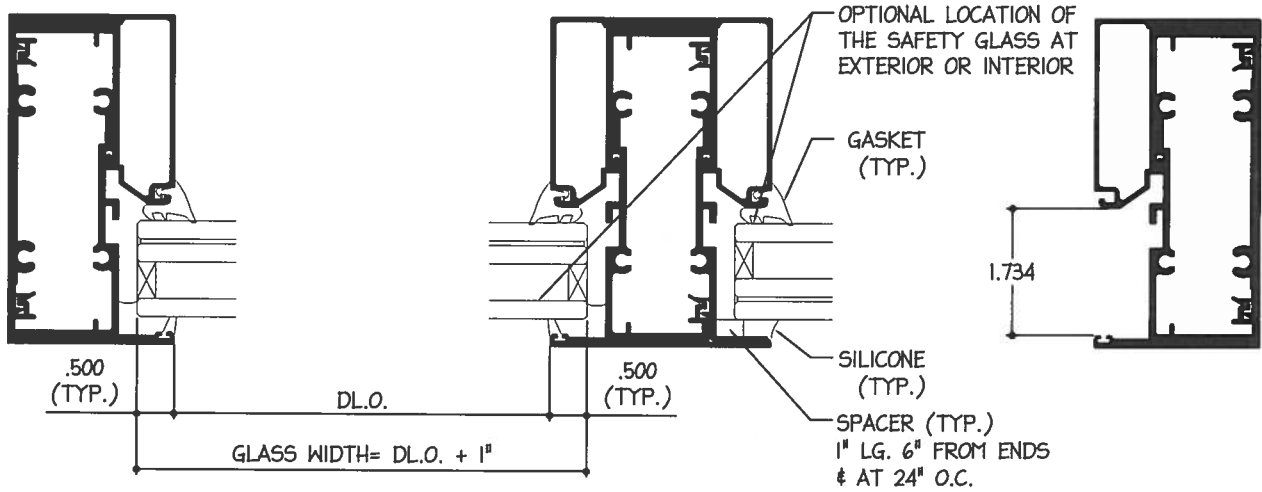

NOMINAL INFILL THICKNESS	EXTERIOR GASKET	INTERIOR GASKET
1 5/16"	SMI-G13	SMI-G01
1 5/16"	SMI-SB03	SMI-G01

EXTERIOR GLAZING GASKETS:



INTERIOR GLAZING GASKET:



SMI-SB07
SETTING BLOCKS
AT 1/4 POINTS UNDER
THE GLASS (TYP.)

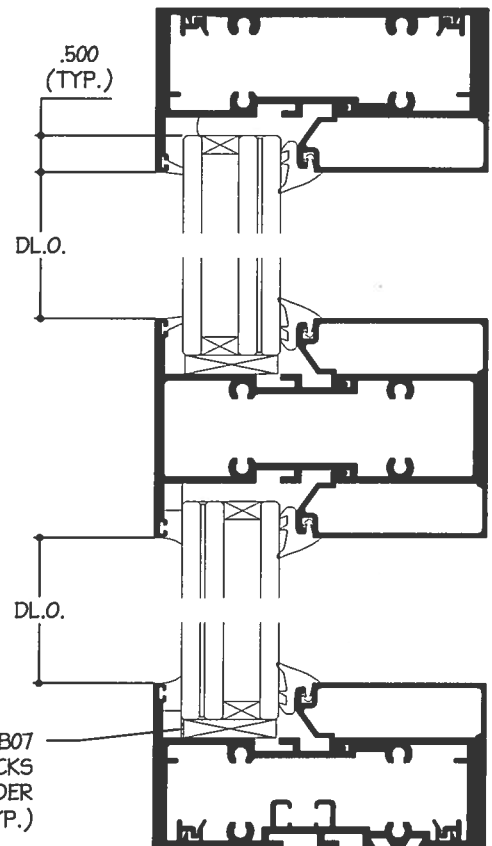

18 INSTALLATION INSTRUCTIONS

FS-300 SYSTEM

GLAZING: 1 5/16" THK. LAM./ INSUL. GL. THERMAL BARRIER

Aldora's front set has an optional thermal break for energy performance. Please specify your thermal break requirement when ordering. The thermal break is most efficient when used with insulated -laminated 1 5/16" hurricane resistant glazing. The glazing pocket measures approximately 1 3/4" in width.

TYPICAL GLASS SIZE IS DAYLITE OPENING (DL.O.) + 1"

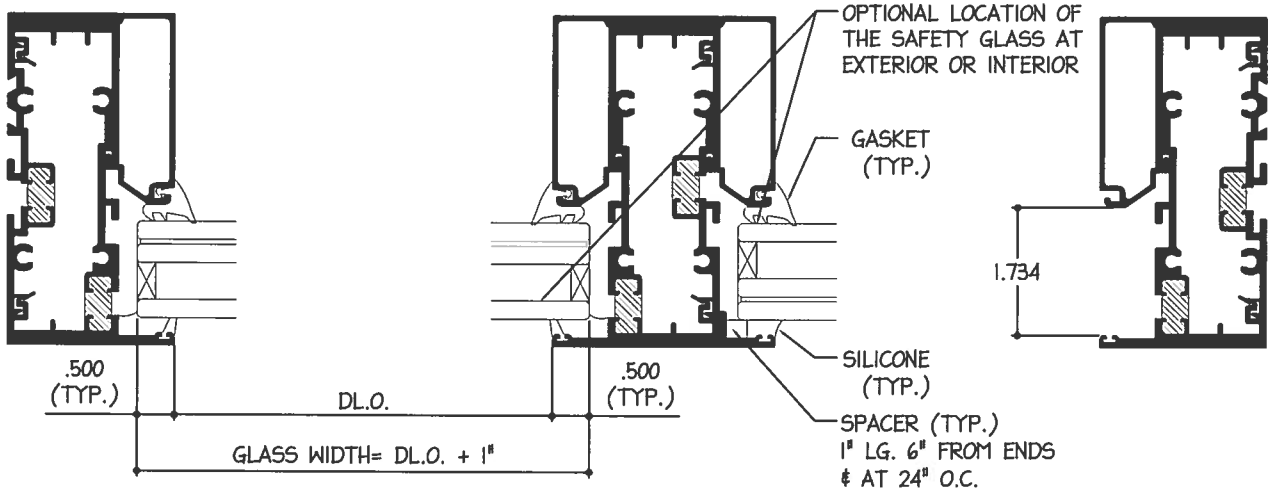

1.734

NOMINAL INFILL THICKNESS	EXTERIOR GASKET	INTERIOR GASKET
1 5/16"	SMI-G13	SMI-G01
1 5/16"	SMI-SB03	SMI-G01

EXTERIOR GLAZING GASKETS:



SMI-G13



SMI-SB03

INTERIOR GLAZING GASKET:



SMI-G01

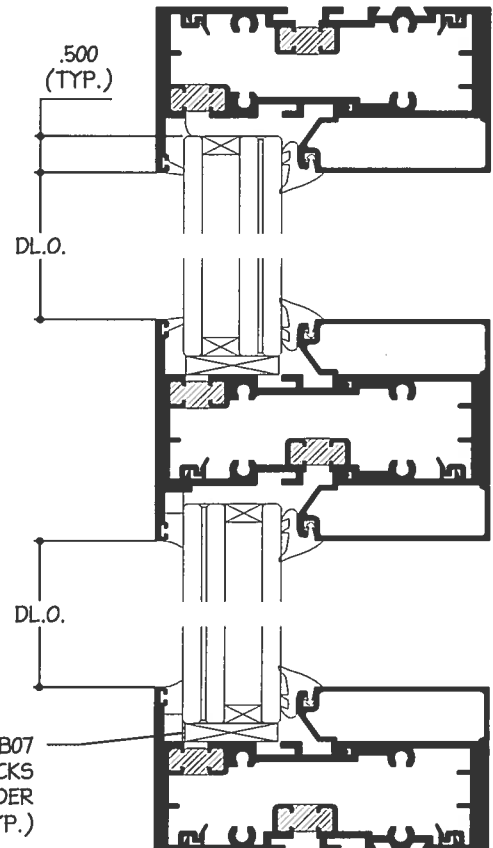

SMI-SB07 SETTING BLOCKS AT 1/4 POINTS UNDER THE GLASS (TYP.)

19 INSTALLATION INSTRUCTIONS

FS-300 SYSTEM
STEEL REINFORCEMENT

The FS300 has multiple steel options depending on the size of the units and the design pressures required. The reinforcements must run the entire length of the vertical member. Please consult with your Aldora representative to ensure you use the proper reinforcement.

All steel must be coated with a corrosion-inhibitor including any cut ends.

STEEL REINFORCEMENT CHART FOR FS-300 (FRONT SET SYSTEM)			
PART #	SPECS	MULLION PART #	UNANCHORED JAMB PART #
ST-FS1	3/8" X 4" STL. BAR	SMI-311T/313T	-
		-	-
ST-FS2	3/4" X 4" STL. BAR	SMI-321/322	-
		SMI-316/317	-
ST-FS3	11/16" X 4" X 11/16" 3/16" THK. FORMED STL. CHANNEL	-	SMI-316
		-	SMI-318

STEEL REINFORCEMENT AT THE STANDARD MULLION
 (WHEN REQUIRED, REFER TO NOA'S CHARTS)

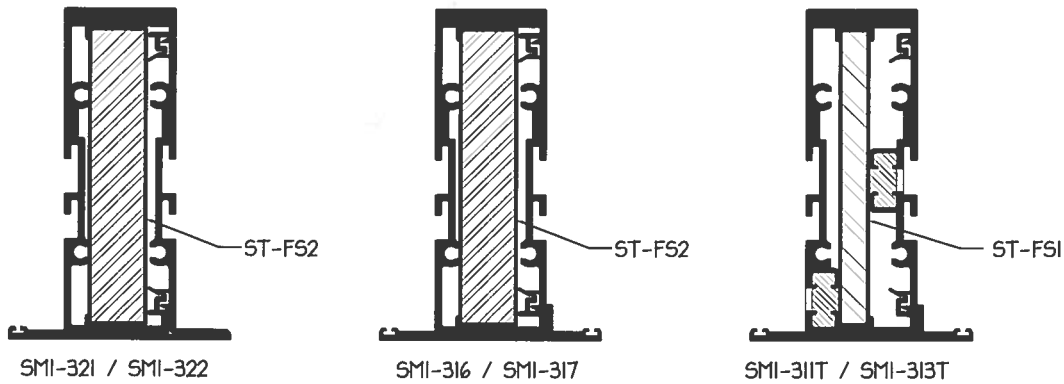

STEEL REINFORCEMENT AT THE UNANCHORED JAMB
 (WHEN REQUIRED, REFER TO NOA'S CHARTS)

